

# CORNING

## Installing Multifiber Pushlok™ Trunks and Mating Multifiber Pushlok Connectors

004-174-AEN, Issue 1

### Table of contents

1. General .....	1
2. Precautions .....	2
3. Tools and Materials .....	2
4. Multifiber Pushlok™ Trunk Installations .....	3
4.2 Aerial Trunk Installations .....	3
4.3 Duct Trunk Installations .....	3
5. Installation.....	4
5.1 Mating Multifiber Pushlok Assemblies to Evolv Terminal Ports.....	4
5.2 Mating Multifiber Pushlok Assemblies.....	7
6. Connector Cleaning.....	8
6.1 Cleaning Evolv Terminal Ports with Pushlok Technology .....	8
6.2 Cleaning Multifiber Pushlok Connector.....	9

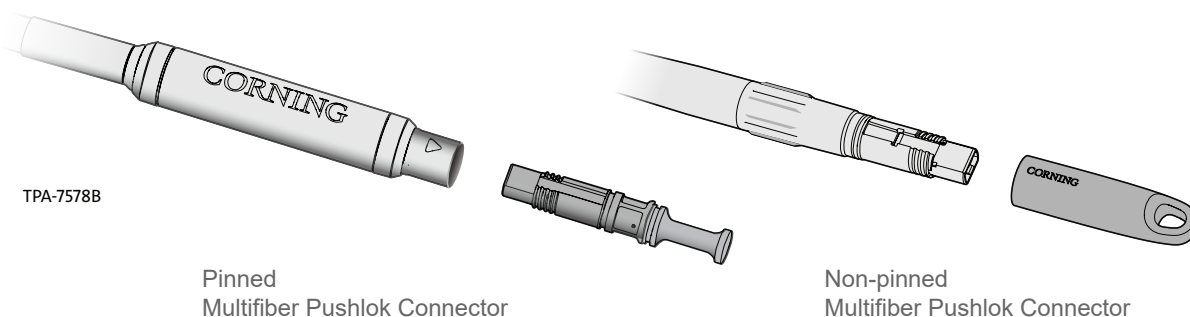

Figure 1

## 1. General

- 1.1 This procedure describes methods for properly installing a multifiber Pushlok trunk in duct and aerial applications and the correct mating of a non-pinned multifiber Pushlok connector to a pinned multifiber Pushlok connector or the multifiber Pushlok terminal port.
- 1.2 Pinned and non-pinned Pushlok connectors are used to create multifiber connections in locations that need environmental protection (Figure 1).
- 1.3 It is very important that the connectors are known to be clean or cleaned prior to connection. A dirty connector will cause attenuation and may damage the connector end-face permanently. Corning Optical Communications factory-assembled multifiber Pushlok connectors have tamper-proof factory seals which verify that the connectors have been cleaned and tested prior to shipping (see Step 3 and Figure 6).

## 2. Precautions

2.1 This section provides safety precautions which should be observed when working with fiber optic products. These practices may change, or may not be suitable in a specific situation, and so are suggested guidelines only. Your company's safety precautions and practices take precedence over any conflicting recommendations given in this document.

### 2.2 Laser Handling Precautions



**WARNING: Never look directly into the end of a fiber or connector that may be carrying laser light.** Laser light can be invisible and can damage your eyes. Viewing it directly does not cause pain. The iris of the eye will not close involuntarily as when viewing a bright light. Consequently, serious damage to the retina of the eye is possible. Should accidental eye exposure to laser light be suspected, arrange for an eye examination immediately.

### 2.3 Safety Glasses



**CAUTION:** Corning Optical Communications recommends the use of safety glasses (spectacles) conforming to ANSI Z87 for eye protection from accidental injury when handling chemicals, cables, or working with fiber.

### 2.4 Cable Handling Precautions



**NOTE :** Fiber optic cable is sensitive to excessive pulling, bending, and crushing forces. Do not bend the cable more sharply than its minimum recommended bend radius. Do not apply more pulling force to the cable assembly than specified. Do not crush the cable or allow it to kink. Doing so may cause damage that can alter the transmission characteristics of the cable; the cable assembly may have to be replaced.



**WARNING:** Unrestrained cable ends may cause injury to your eyes or body and damage the cable, connector, or fibers if suddenly released from a coil. Wear eye protection and use extreme care when handling a coiled cable assembly which uses drop cable - gently release the energy stored in the cable coil to avoid possible personal injury or damage to the cable or connector components. (Figure 2).

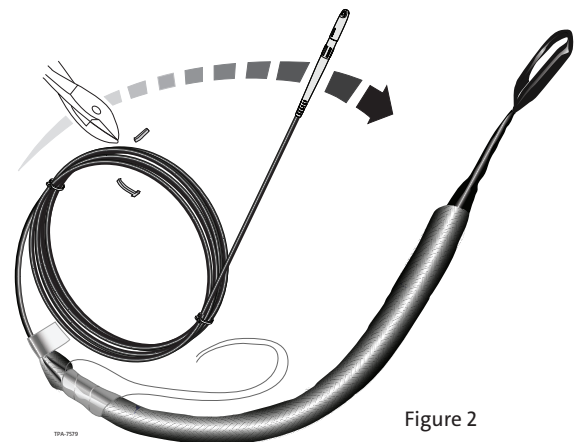

Figure 2

## 3. Tools and Materials

3.1 The following tools and materials may be required to complete the installation sections of this procedure:

- Side cutters (diagonal cutting pliers)
- Scissors
- Cable ties
- Pull tape
- Pull line

3.2 The following tools and materials may be required to complete the connector mating sections of this procedure:

- Multifiber Pushlok™ cleaning tool (CLEANER-PUSHLOK-MF)

## 4. Multifiber Pushlok™ Trunk Installations

- 4.1 When placing a multifiber Pushlok™ trunk in duct or aerial environments, plan the installation to pull from the non-pinned multifiber connector's pulling eye (Figure 3).

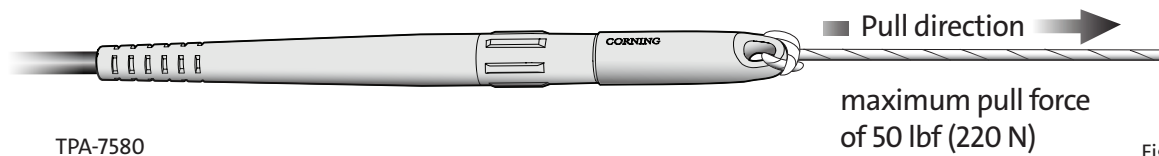
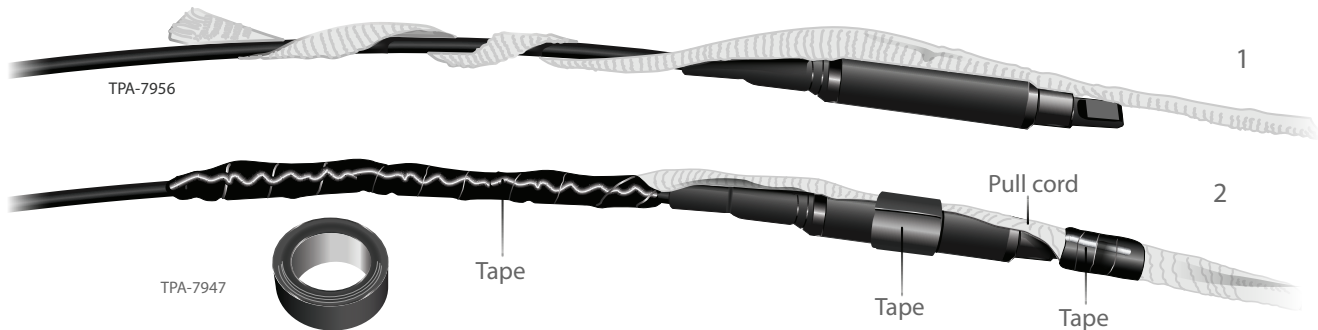

Figure 3

**NOTE:** The dust cap on the non-pinned Pushlok connector has a pulling eye built in. Connect this eye to the pull string to install the cable into the duct. Ensure that you do not exceed 50 lbf tension on the cable. It is also recommended to use a swivel between the pull string and connector assembly, or apply tape around the connector, from the pull string to the boot. The non-pinned Pushlok connector is designed to be pulled in a 3/4 inch duct or larger.



**NOTE:** The pinned Pushlok connector does not have an integrated pulling eye. To pull from this end, it is suggested to attach the pull string to the cable behind the connector, as shown in the illustration above. Be sure to tape the connector to the string, so that it does not get damaged during installation. It is also recommended to use a swivel when pulling this assembly. The pinned Pushlok connector is designed to be pulled in a 1 inch duct or larger.

## 4.2 Aerial Trunk Installations

**NOTE:** Skip to Step 4.3 if your installation is a duct application.

- Step 1:** Pull the trunk to the final pole, ensuring that you do not exceed 50 lbf (220 N) of force on the cable. If the cable is running multiple pole spans, hang the proper diameter roller at the intermediate poles during placing. Once the full run is placed, start at the head-end and lash the cable.



**CAUTION:** Do not place drip loops in the cable during installation. Forming a drip loop in the cable will most likely exceed the bend radius or break the cable's strength members, causing fiber damage and attenuation.

## 4.3 Duct Trunk Installations

- Step 1:** Pull the trunk through the duct to the final handhole ensuring that you do not exceed 50 lbf (220 N) (Figure 4).

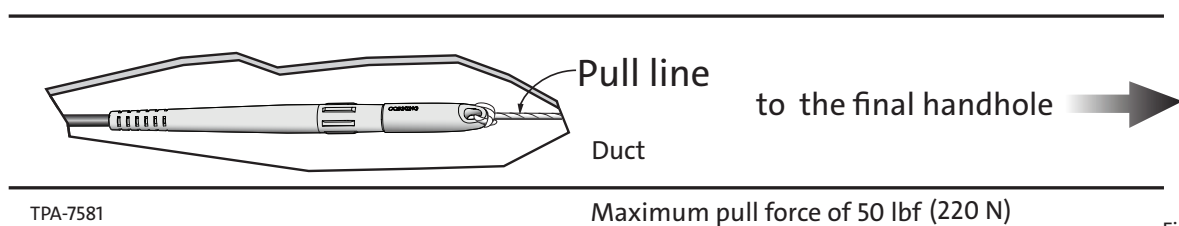

Figure 4

4.4 The terminal or multifiber Pushlok™ connector in the handhole may be covered with mud or dirt due to normal ground water or flooding. Although these contaminants will not affect the performance of the unit, clean the unit before removing the unit's plugs to prevent contamination of the multifiber Pushlok connector end-face:

- Step 1:** Remove any cable ties or fasteners binding the terminal and its cable stub.
- Step 2:** For light dirt and dust, soak a clean rag or towel with clean water and gently clean the housing. Wipe dry with a clean, dry rag or towel.
- Step 3:** For heavy, caked-on mud and dirt, spray the housing with low-pressure water such as a garden sprayer outside of the handhole. A soft-bristle brush may also be used to lightly scrub the housing to loosen the mud and dirt. Remove any remaining dirt with a water-soaked rag or towel and wipe dry with a clean rag or towel.
- Step 4:** **IMPORTANT:** *Only use clean water to wash the terminal or connector. Do not use any type of solvent. When handling the terminal/connector, support it and its cable to prevent kinking the cable at the entrance of the terminal/connector.*
- Step 5:** Although the terminal/connector should now be generally clean, there may still be dirt particles around the multifiber Pushlok connector/port. Therefore, before removing a dust cap, first turn the terminal/connector so that the dust cap faces downward and then unscrew the selected cap. In this way, any stray dirt particles will fall to the ground instead of into the connector.

## 5. Installation

### 5.1 Mating Multifiber Pushlok Assemblies to Evolv® Terminal Ports

- Step 1:** Depress the button for the port and pull out the dust plug.

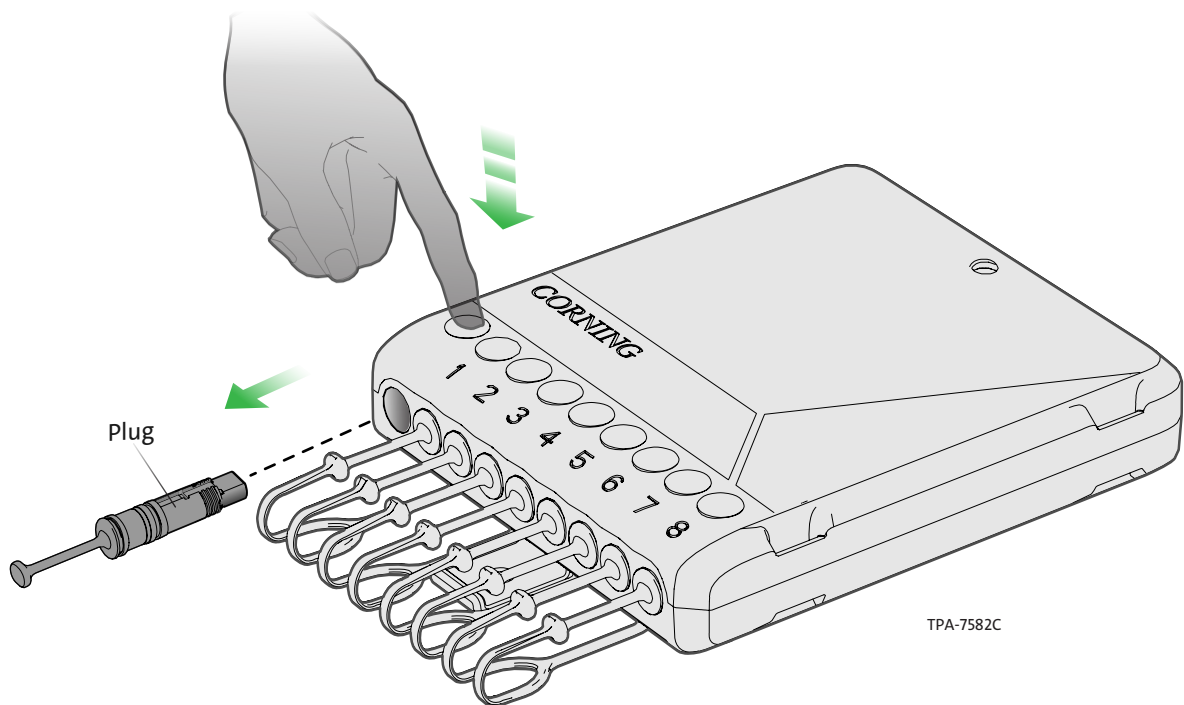

**Step 2:** Follow Section 6.1 to clean the terminal port below.

**Step 3:** The Pushlok™ multifiber connector comes clean from the factory. If the seal is not broken, the connector does not need to be cleaned prior to mating (Figure 4). If cleaning needs to happen, follow the steps in Section 6.2.

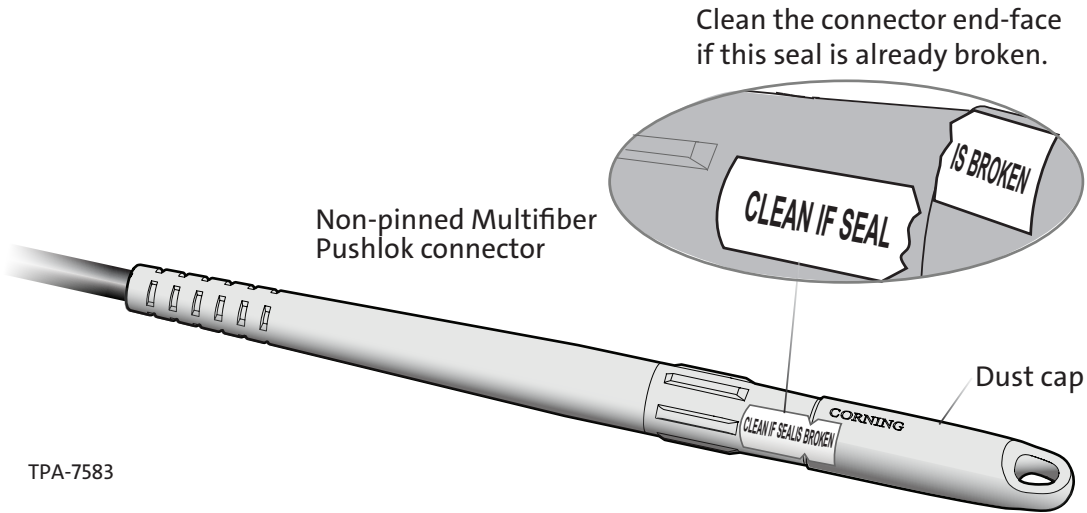
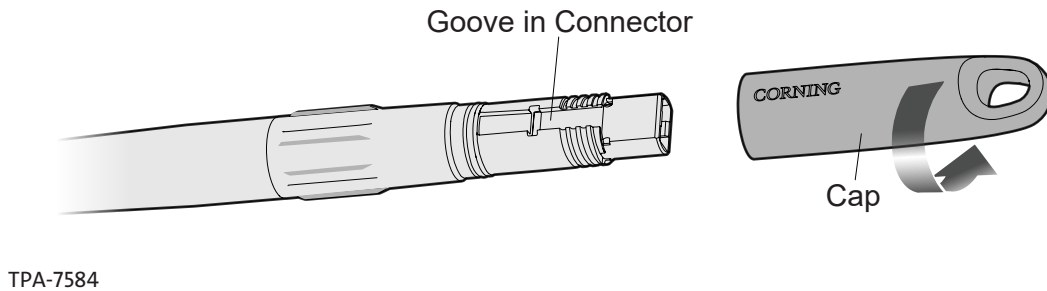

Figure 4

**Step 4:** Unscrew the non-pinned multifiber Pushlok dustcap. Locate the alignment groove on the connector.



**Step 5:** Align the notch on top of the connector with the port button on the terminal. (Figure 5)

**Step 6:** Insert the drop connector into the terminal port, until the button clicks and the latch is engaged. (Figure 6)

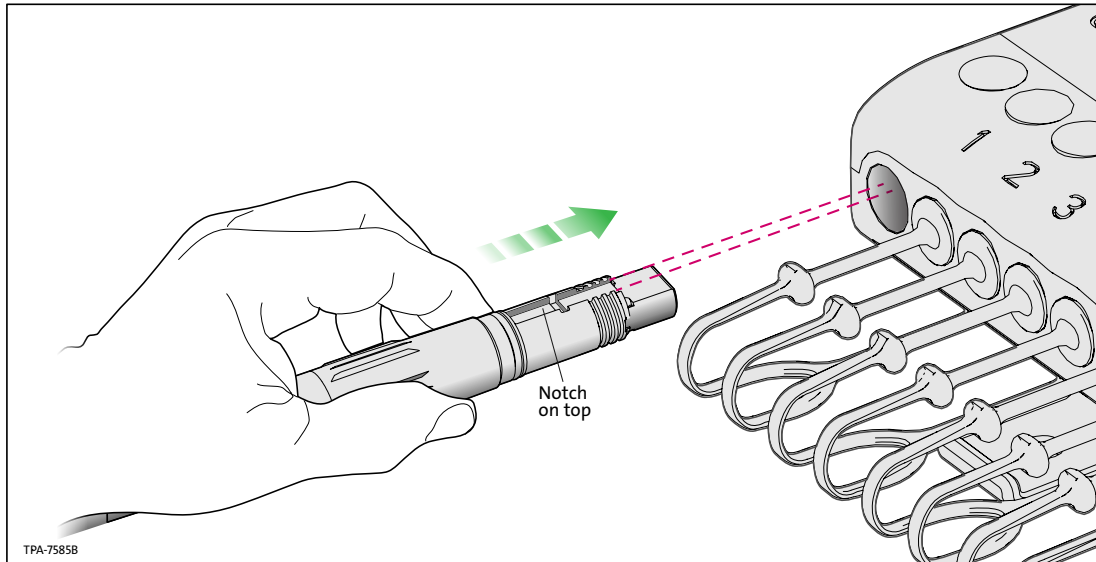

Figure 5

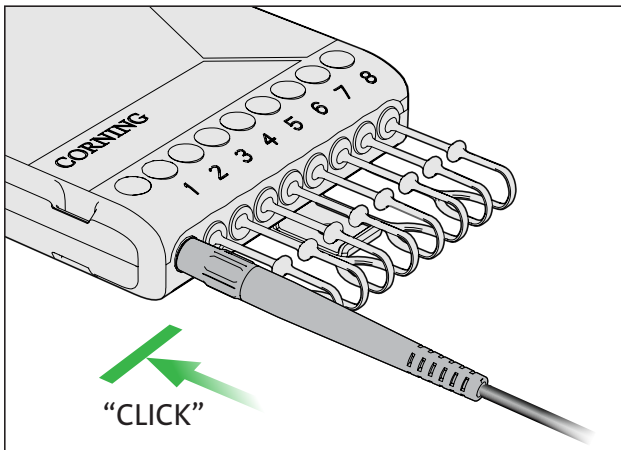

Figure 6

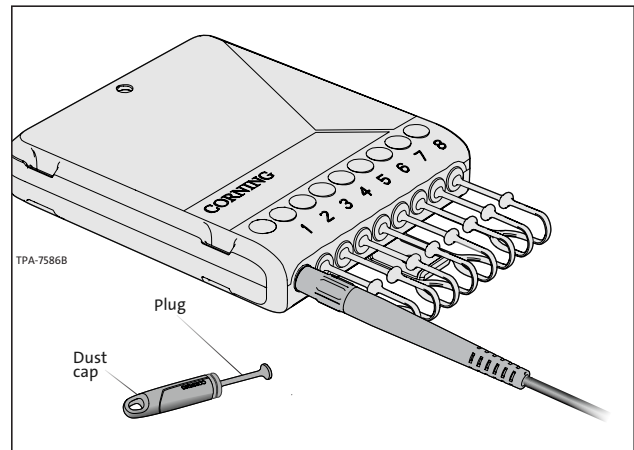

Figure 7

**Step 7:** Connect the terminal port dust plug with the connector dust cap (Figure 7).

**Step 8:** Repeat Section 7.3 for all connectorized drop cables.

**Step 9:** Manage any cable slack per standard local practices.

## 5.2 Mating Multifiber Pushlok™ Assemblies

**Step 1:** Depress the button on the pinned multifiber Pushlok connector and pull out the dust plug.

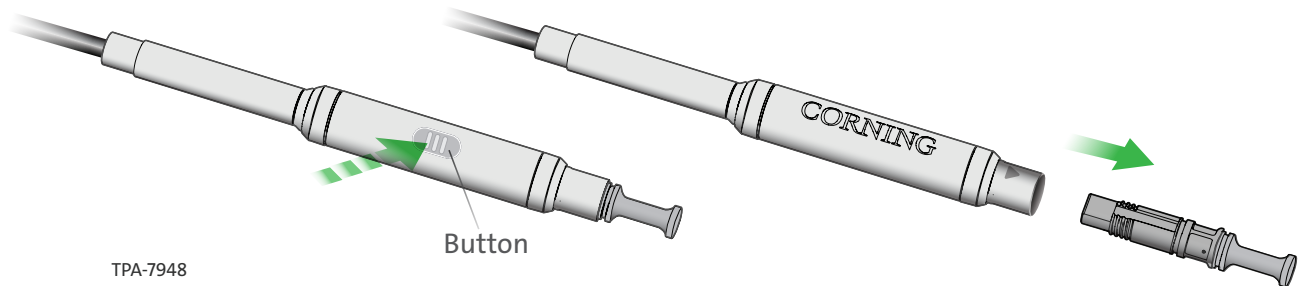

**Step 2:** The Pushlok multifiber connector comes clean from the factory. If the seal is not broken, the connector does not need to be cleaned prior to mating. If cleaning needs to happen, follow the steps in Section 6.2

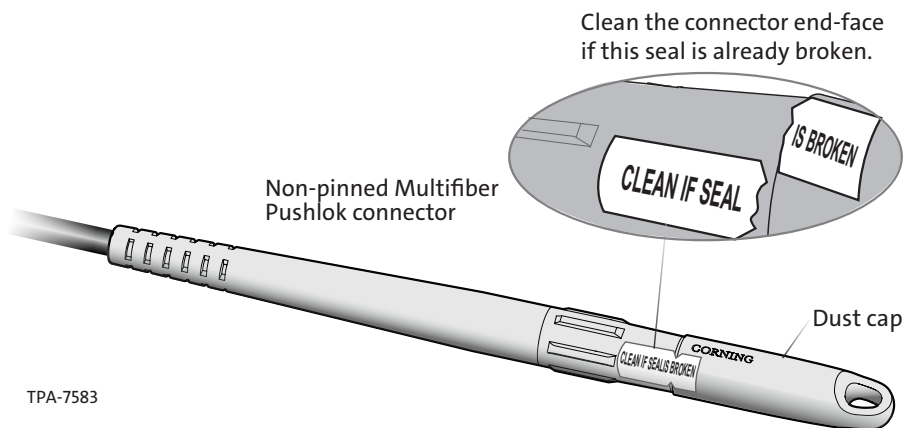

**Step 3:** Unscrew the non-pinned multifiber Pushlok dust cap. Locate the alignment groove on the connector.

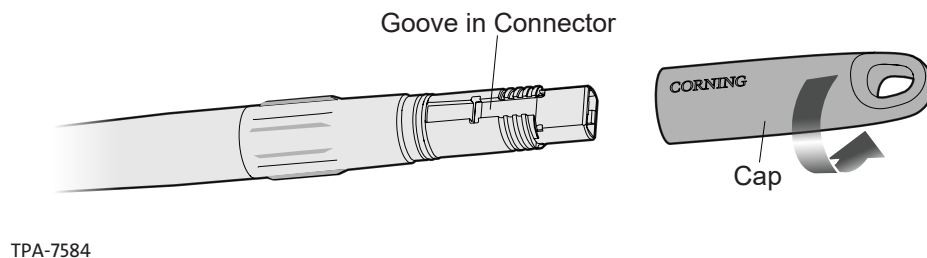

**Step 4:** Align the groove in the non-pinned connector with the arrow of the pinned connector and insert the non-pinned connector into the pinned connector.

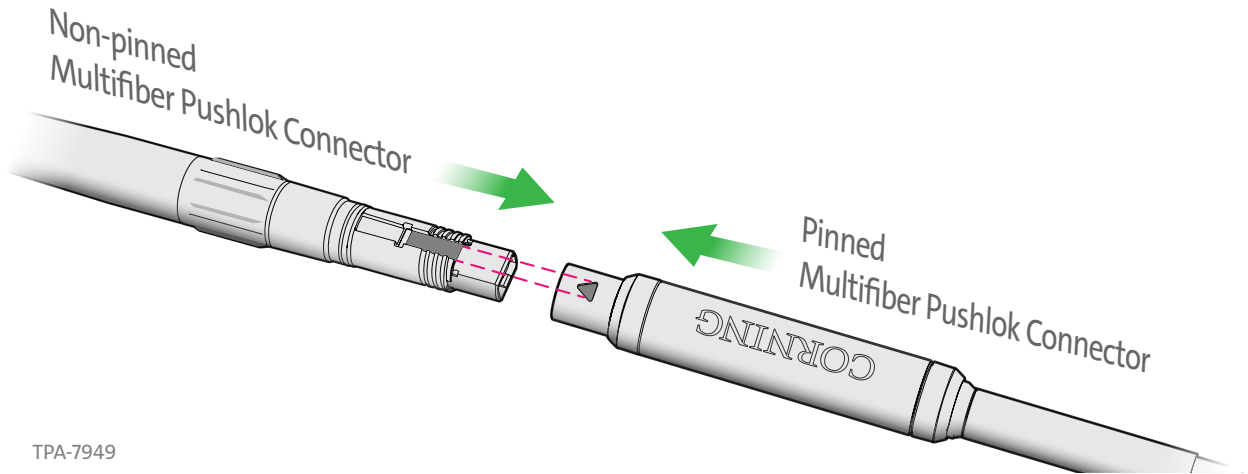

TPA-7949

**Step 5:** Manage any cable slack per standard local practices.

## 6. Connector Cleaning

### 6.1 Cleaning Evolv™ Terminal Ports with Pushlok™ Technology

**NOTE:** Use of multifiber port cleaner (CLEANER-PUSHLOK-MF) is approved for cleaning connectors and ports.

**Step 1:** Remove the protective plug from the port where the connector will be mated (Section 5.1, Step 1).

**Step 2:** Insert the multifiber port cleaner, until it clicks, to clean the connector inside the port as shown below.

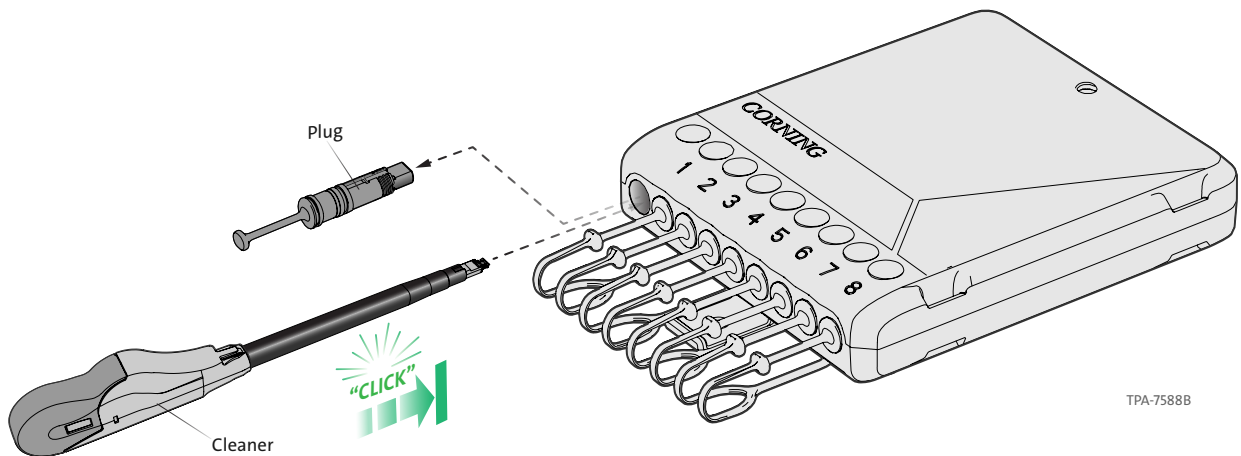

TPA-7588B

**Step 3:** Replace the dust plug, or follow the instructions in Section 5 for mating the connectors.



## 6.2 Cleaning Multifiber Pushlok™ Connector

**NOTE:** Use of multifiber Pushlok cleaner (CLEANER-PUSHLOK-MF) is approved for cleaning connectors and ports.

### 6.2.1 Cleaning Non-Pinned Multifiber Pushlok Connector

**Step 1:** Remove the dust cap from the non-pinned connector (Section 5.2, Step 4).

**Step 2:** Align the keyway on the non-pinned connector with the key on the cleaner adapter. Insert the connector into the cleaner and push until it clicks.

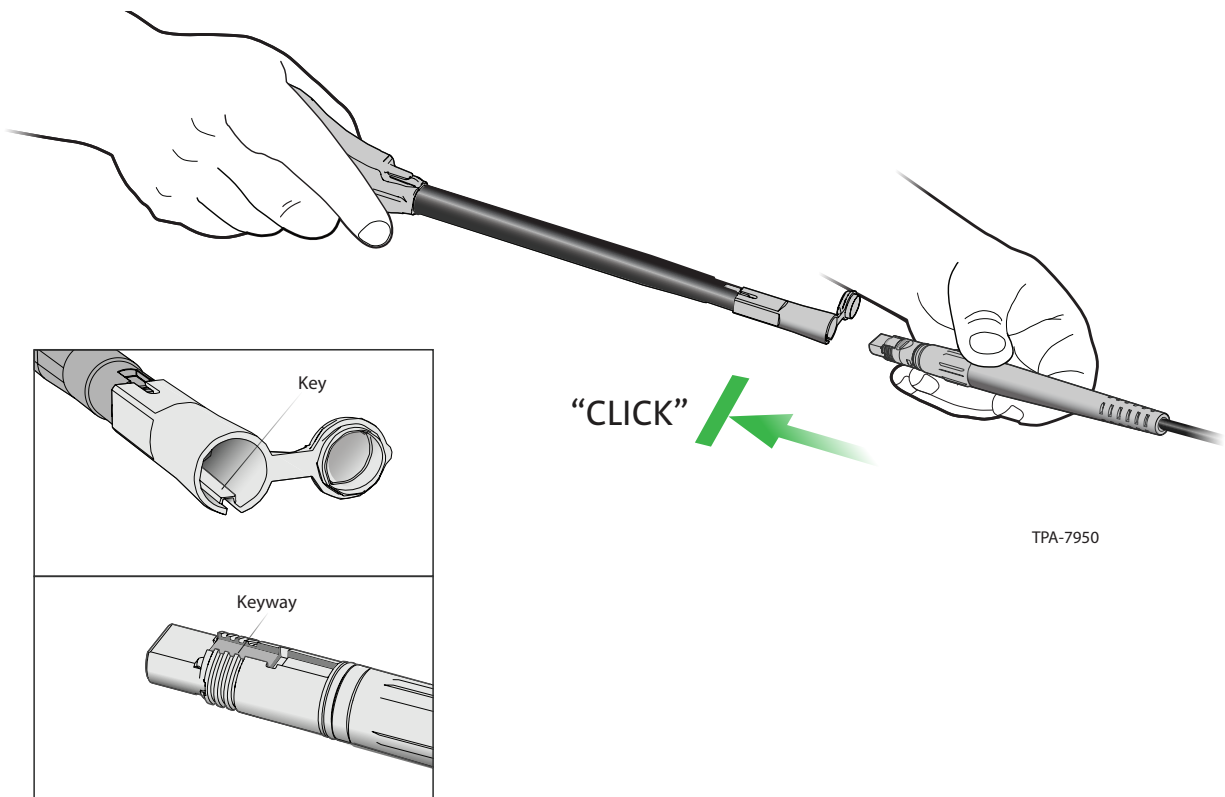

**Step 3:** Remove the cleaner and replace the connector dust cap.

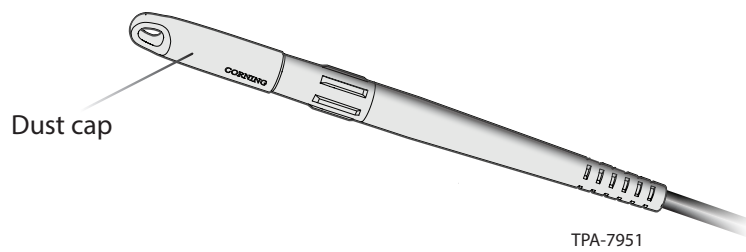

**Step 4:** Follow instructions in Section 5 for mating the connectors.

## 6.2.2 Cleaning Pinned Multifiber Pushlok™ Connectors

**Step 1:** Remove the dust plug from the pinned connector (Section 5.2, Step 1).

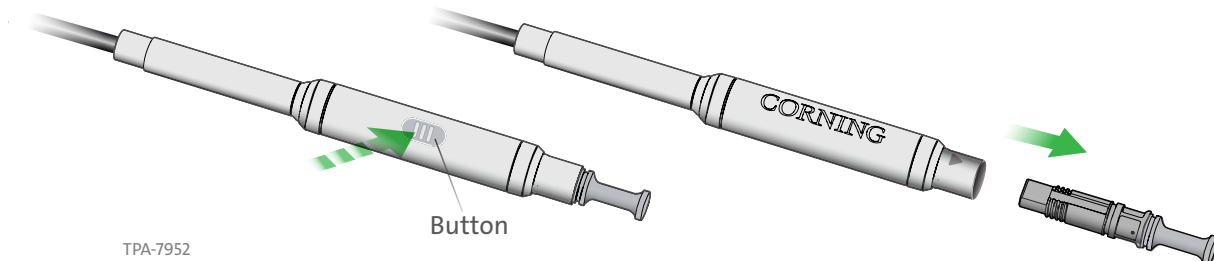

**Step 2:** Remove the adapter from the end of the cleaner.

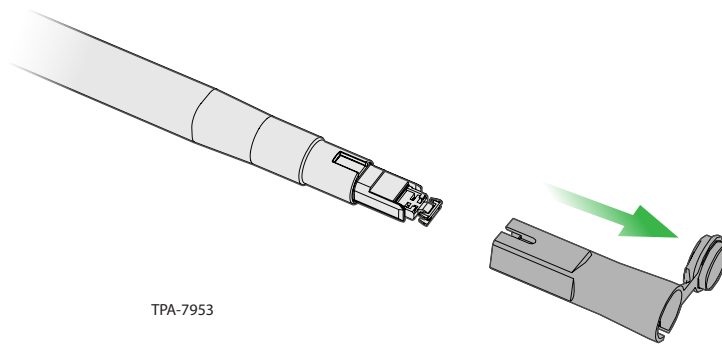

**Step 3:** Align the groove in the cleaner with the arrow on the connector and insert into the connector. Push on the cleaner until it clicks.

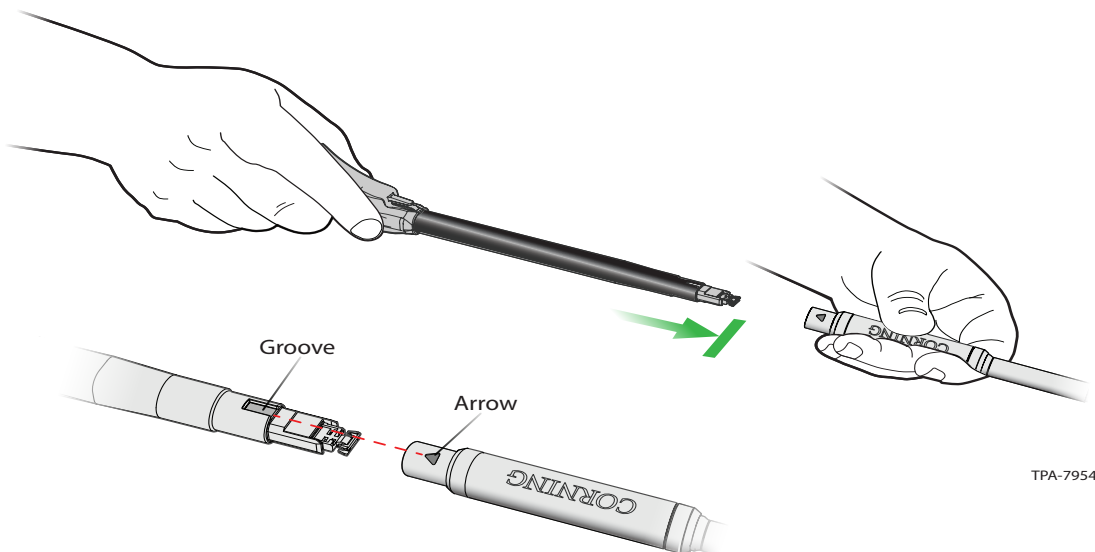

**Step 4:** Remove the cleaner and replace the connector dust plug.

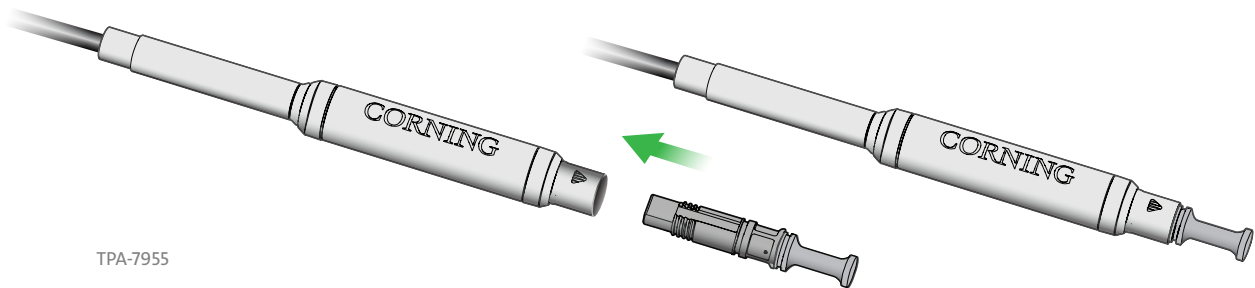

**Step 5:** Follow instructions in Section 5 for mating the connectors.